

Schema idraulico  
Hydraulic diagram

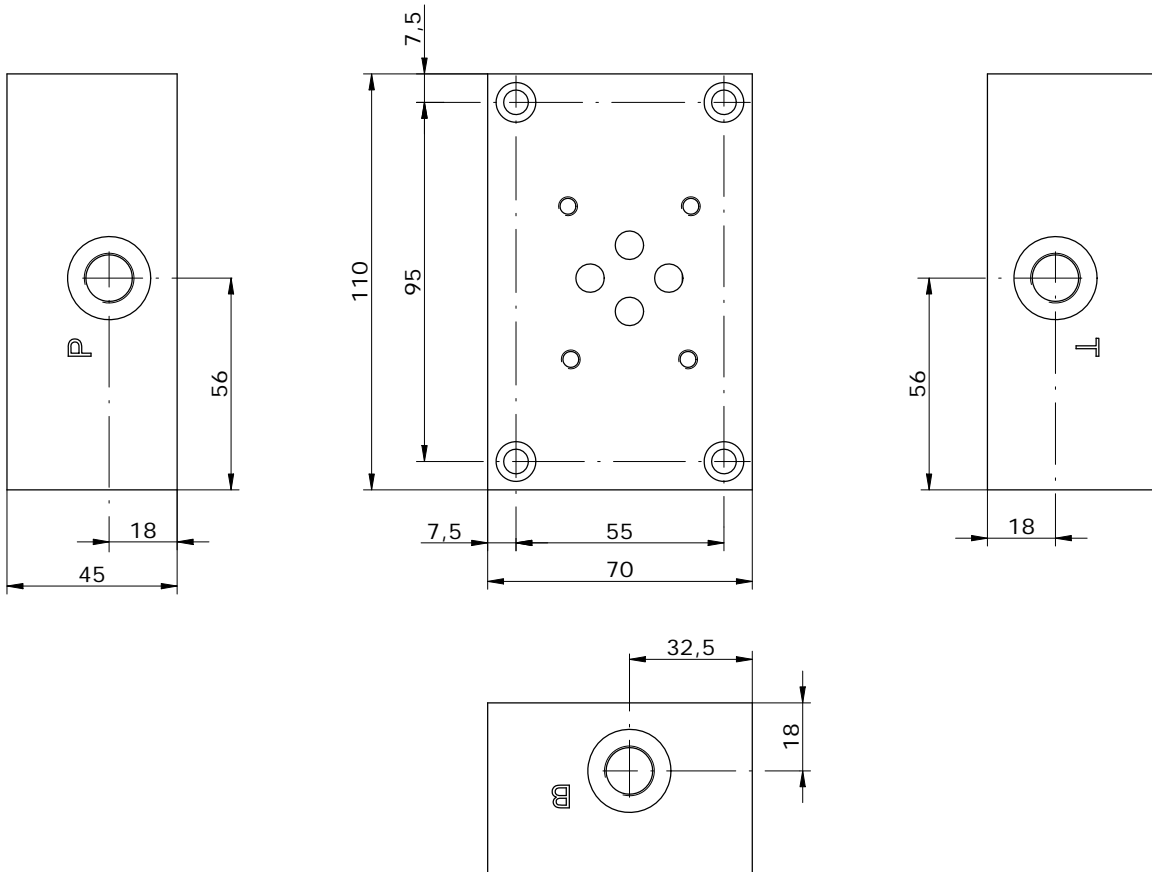
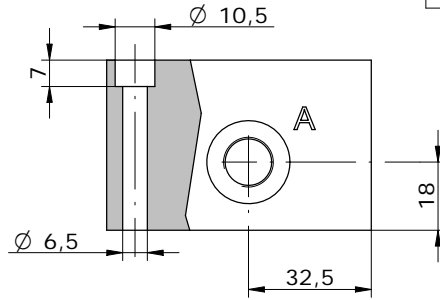
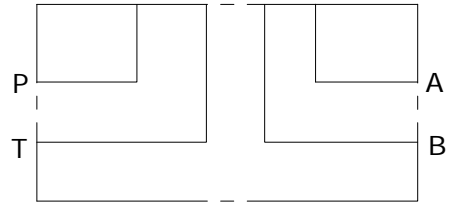

**E\_ 06 - 09 -** \_\_\_\_\_

**S** = STEEL  
**A** = ALUMINUM

**14** = BSP 1/4G  
**38** = BSP 3/8G  
**12** = BSP 1/2G